

Name _____

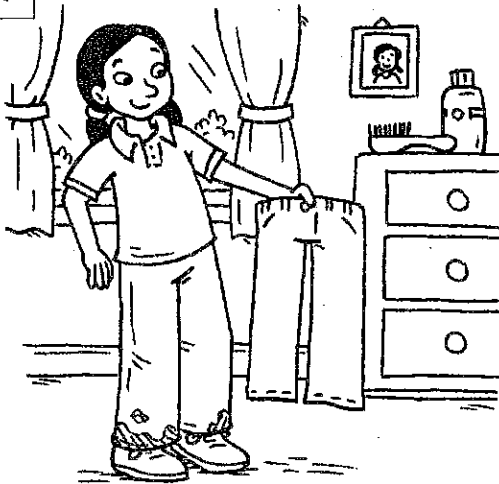
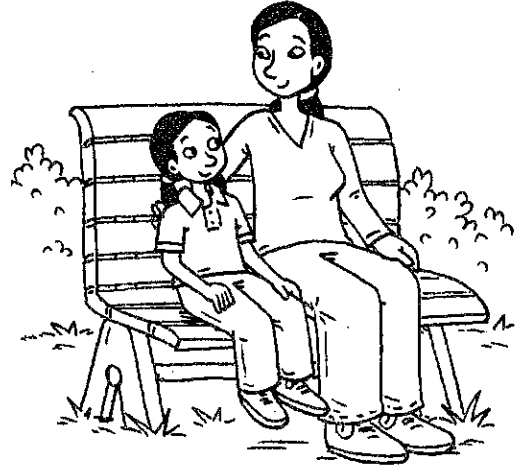

Directions: Have children recall the story about Karen and her mother. Then have them circle the pictures that show their guesses, or predictions, about the story. Ask the children to retell the story to one another.

Name _____

High-Frequency
Words: /

.....
Lesson 1 Day 2



Directions: Read the unfinished phrase with children and have them draw a picture to complete the phrase. Then have them read the phrases again.

Name _____

Comprehension:
Make Predictions
.....
Lesson 1 Day 3

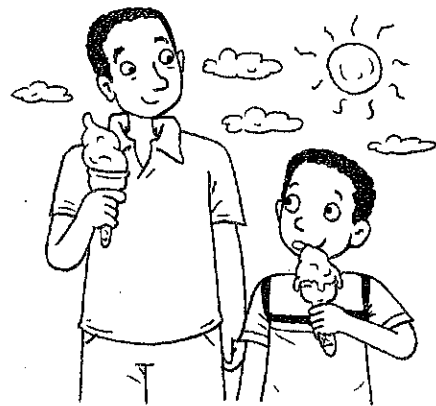
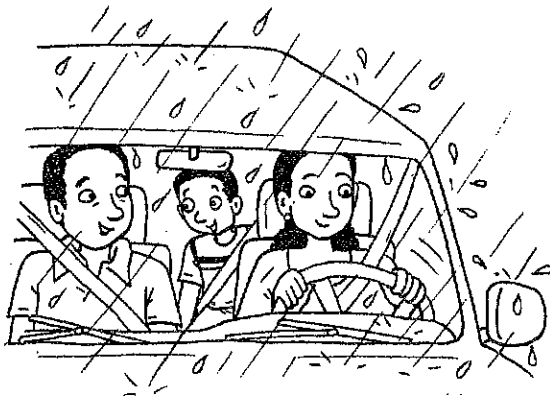
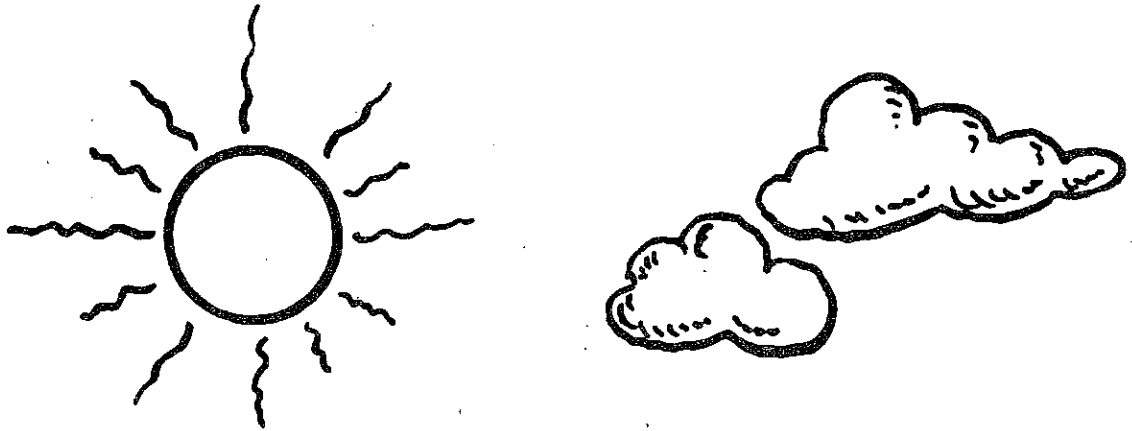

Directions: Have children circle the pictures that show their predictions, or guesses, about what might happen in the story about Sam and his dad. Then have them retell the story to one another.

© Harcourt

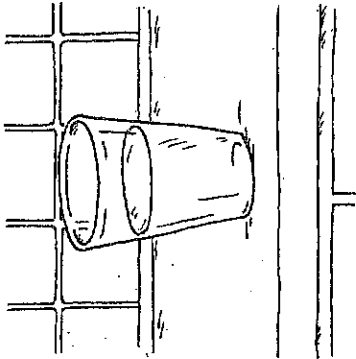

Dear Family Members,
This Take-Home Book contains words your child is learning. After reading the story with your child, encourage him or her to read it to you. Then talk about your child's favorite drink or snack.

8



6

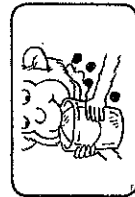

I

!

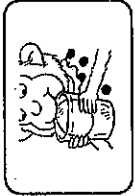

I

!



1

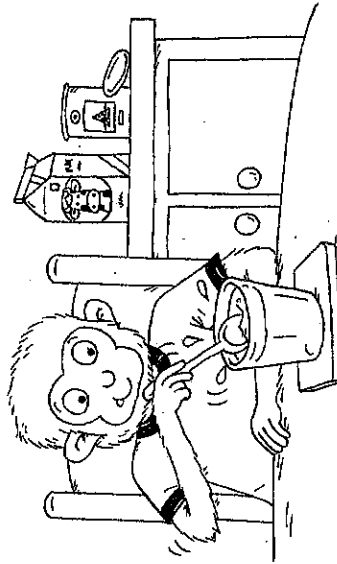

I

3

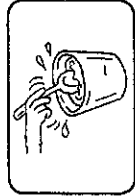

Directions: Help children cut and fold the book.

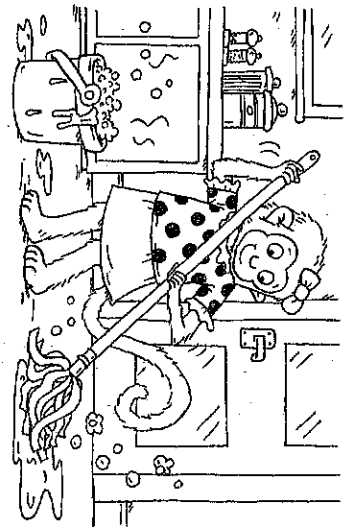

Fold

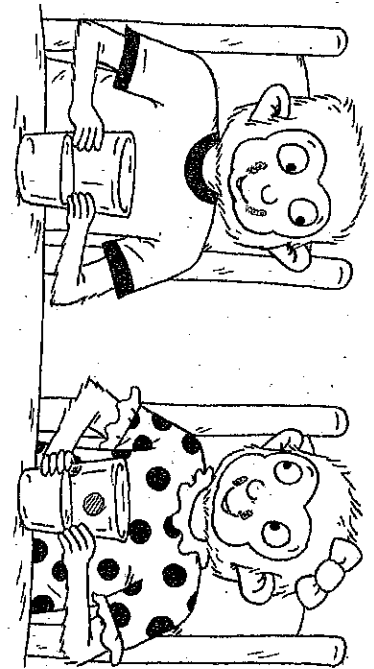

Mmmmm!



6

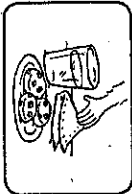
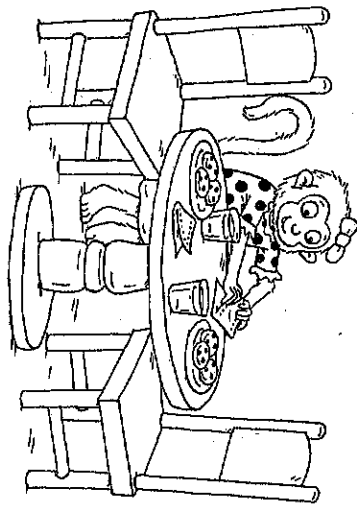

Fold

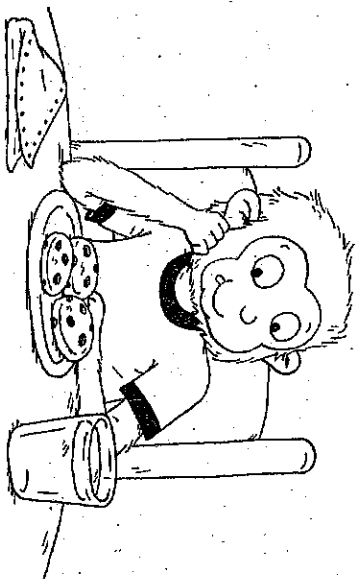

6

Name _____

Phonics: Rr
.....
Lesson 1 Day 5

Rr

r

s

r

R

r

m

R

M

S

R

R

r

R

r

Directions: Have children circle each uppercase R and underline each lowercase r. Then have them trace each letter and practice writing it on the line.

Name _____

Comprehension:
Make Predictions
.....
Lesson 2 Day 1

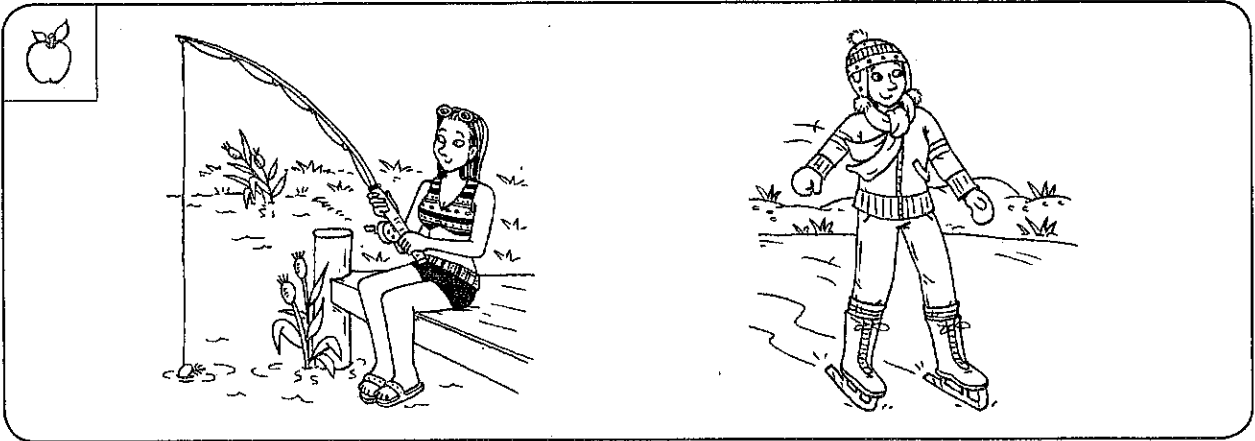

Directions: Have children recall the story about Mary. Then have them circle the pictures that show their predictions about the story. Ask the children to retell the story to one another.

Name _____

High-Frequency
Words: a
.....
Lesson 2 Day 2



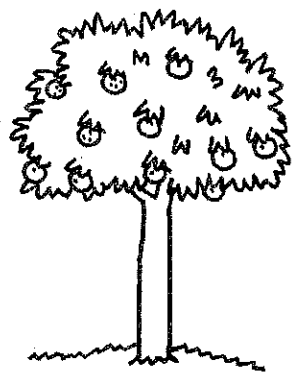

a



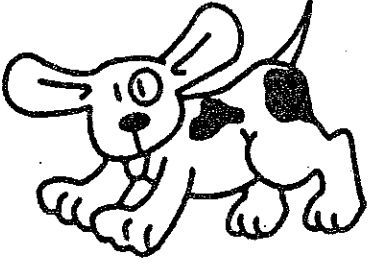

a



a

Directions: Read each phrase and have children trace the words. Then have them draw a picture in the box to make a new phrase. Have them read their phrases.

Name _____

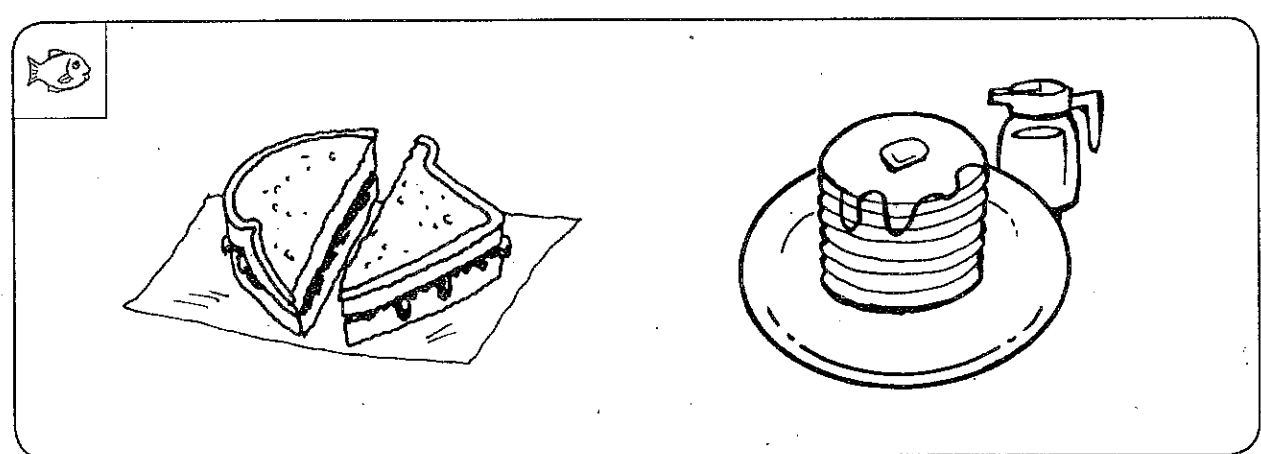
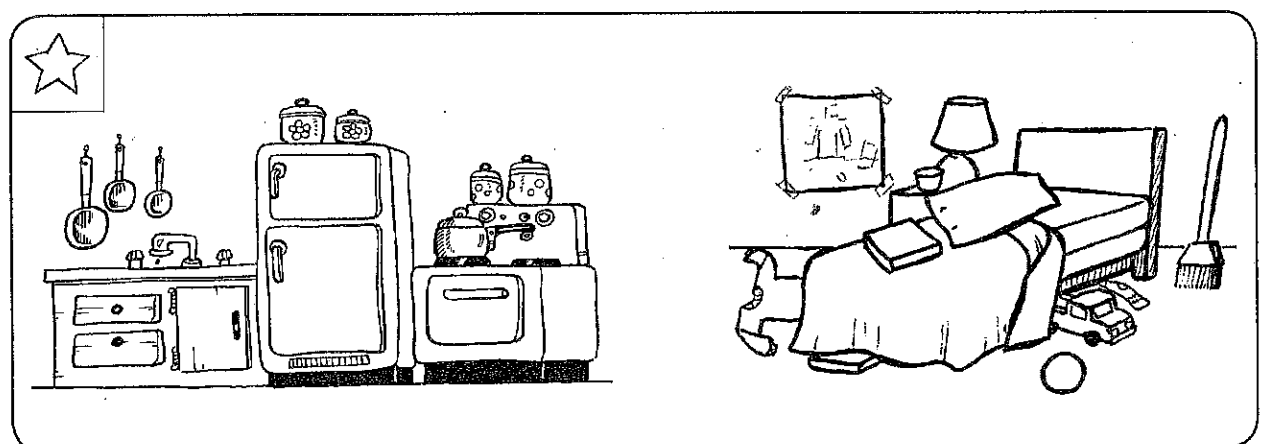
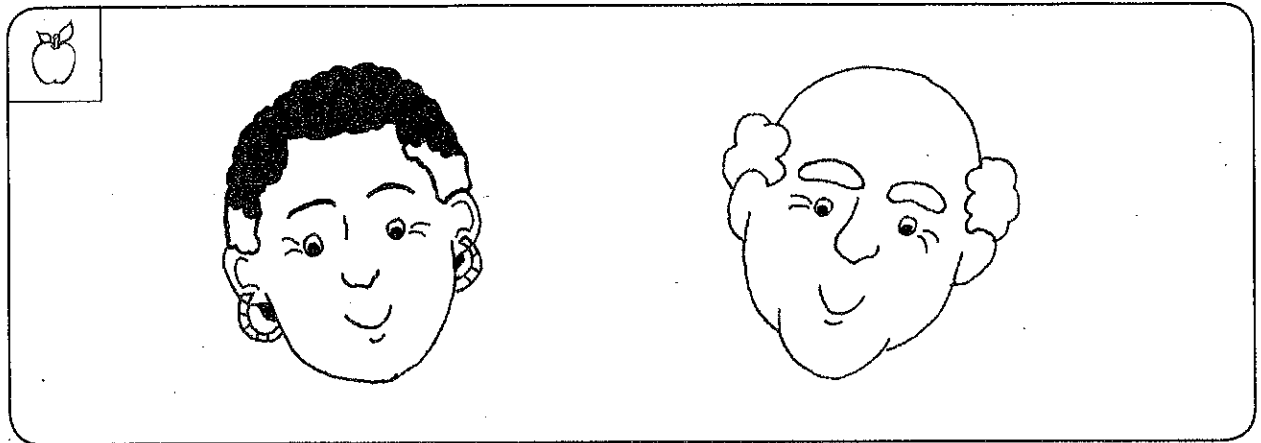

Directions: Have children circle the pictures that show predictions about the story about Priscilla.
Then have them retell the story to one another.

© Harcourt

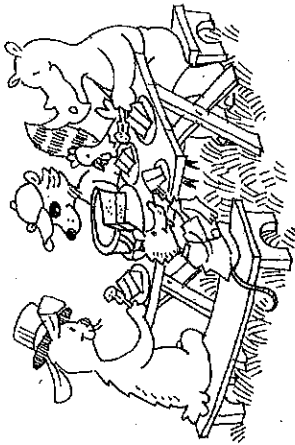

Dear Family Members,
This Take-Home Book contains words your child is learning. After reading the story with your child, encourage him or her to read it to you. Then talk about picnics you and your child have attended.

8

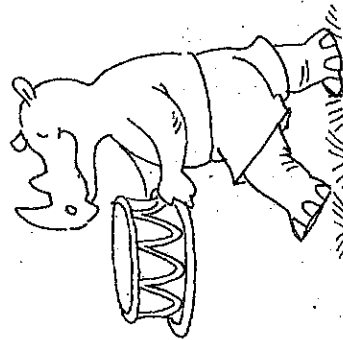

a

6

Fold

Fold



a

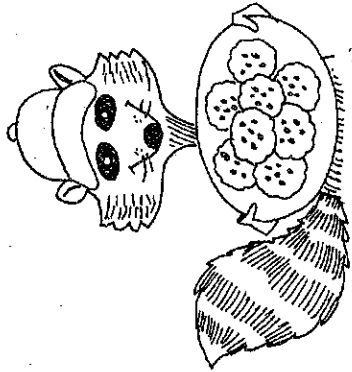

1

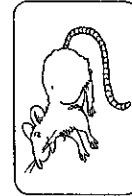

a

3

Directions: Help children cut and fold the book.

4

Q

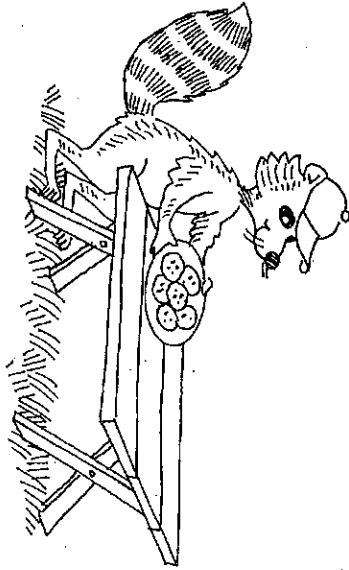

2

Q

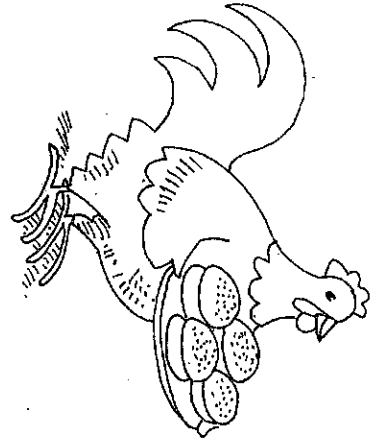

Fold

Fold

Q

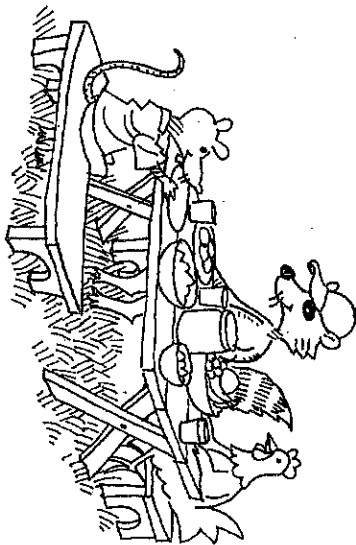
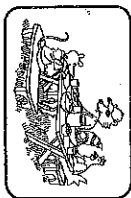

Q



5

7

Name _____

Phonics: Tt
.....
Lesson 2 Day 5

Tt

o t b x t

T L G T u

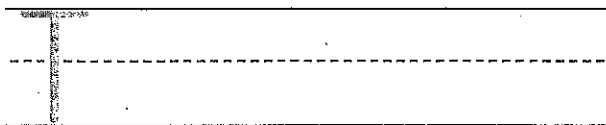
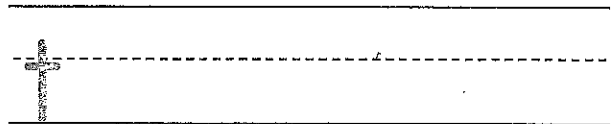
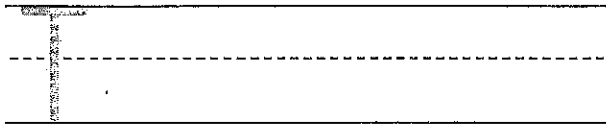

Directions: Have children circle each uppercase T and underline each lowercase t. Then have them trace each letter and practice writing it on the line.

Name _____

Comprehension:
Make Predictions
.....
Lesson 3 Day 1

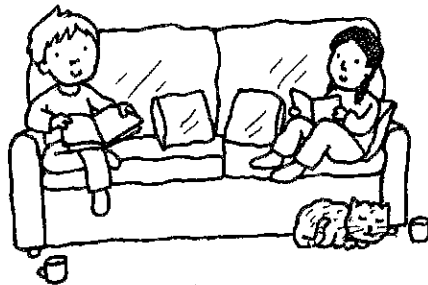
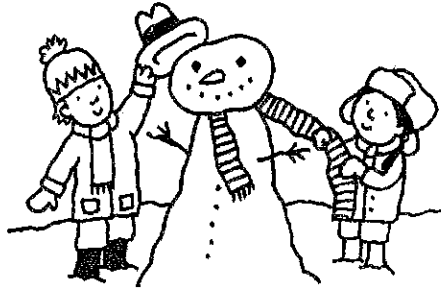

Directions: Have children circle the picture that shows their guess for what might happen next in the story. Have them use clues from the story to explain their prediction.

Name _____

High-Frequency
Word: *my*
.....
Lesson 3 Day 2



a

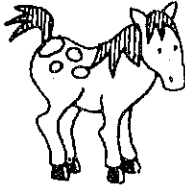

a

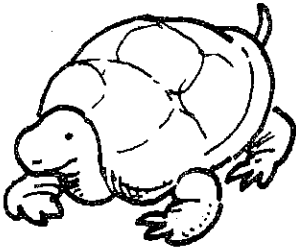

my

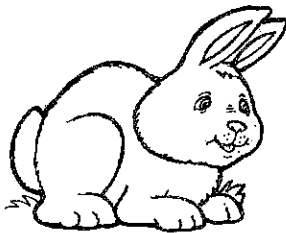

my

Directions: Read the first three phrases with children. Then have them read the last phrase and draw a picture to show an animal they like. Then have them read the phrases again.

Name _____

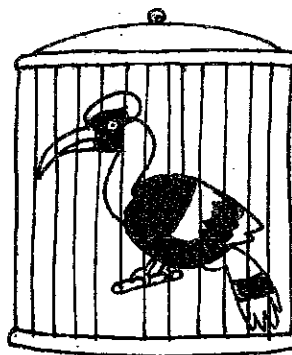
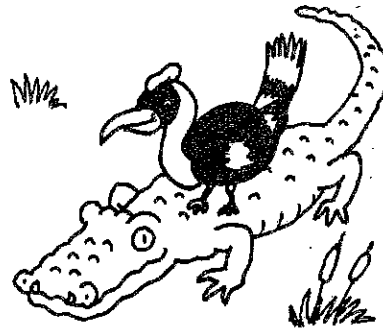
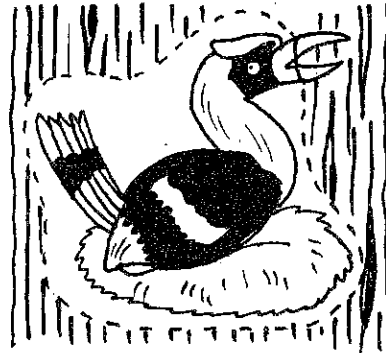

Directions: Have children circle the picture that shows their guess for what might happen next in the story. Have them use clues from the story to explain their prediction.

© Harcourt

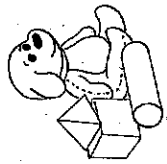

Dear Family Members,
This Take-Home Book contains words your child is learning. After reading the story with your child, encourage him or her to read it to you. Then talk about one of your child's friends and how they play.

8

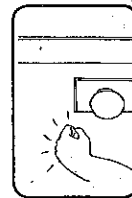
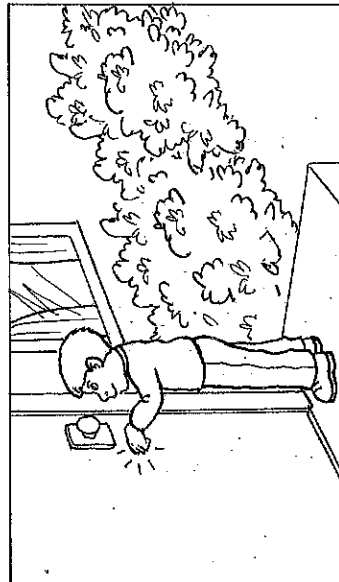

a

6

Fold

Fold

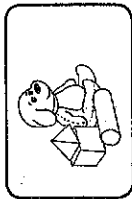

my

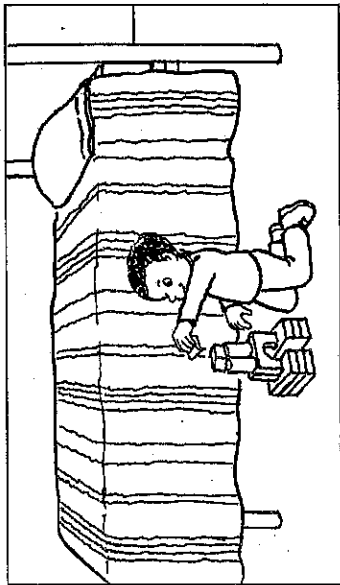

1

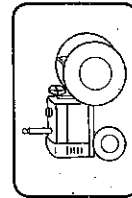
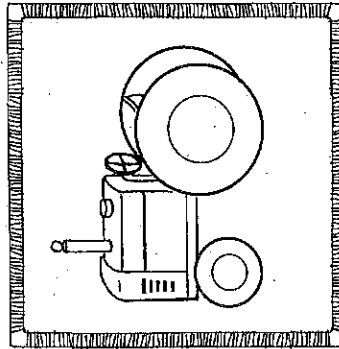

my

3

Directions: Help children cut and fold the book.

4

my

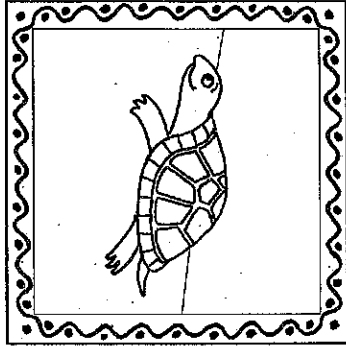
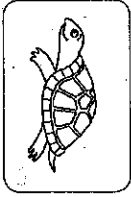

Fold

my

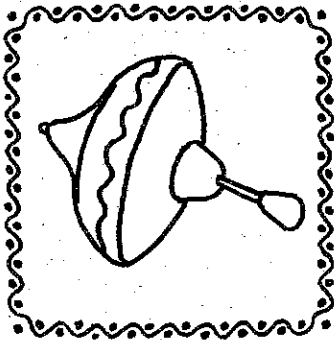
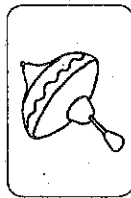

5

2

my

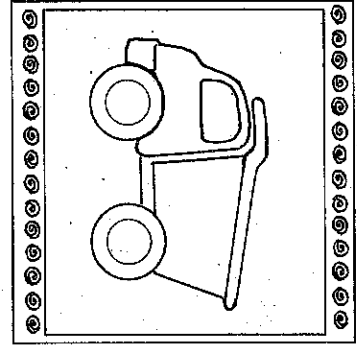
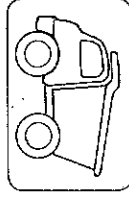

Fold

my

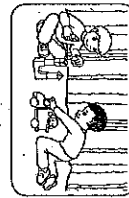

7



Name _____

Phonics: Nn
.....
Lesson 3 Day 5

N n

N n r T N

m s n N o

N n
N n

Directions: Have children circle each uppercase *N* and underline each lowercase *n*.
Then have them trace each letter and practice writing it on the line.

Name _____

Comprehension:
Characters
.....
Lesson 4 Day 1

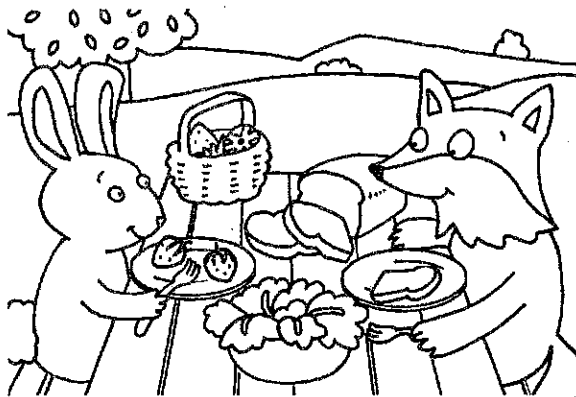
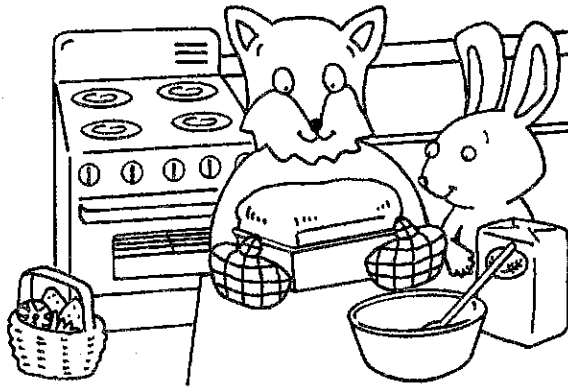

Directions: Have children use the pictures to name and tell about the characters in the story. Then have them retell the story to one another.

Name _____

High-Frequency
Words: *the*
.....
Lesson 4 Day 2



the

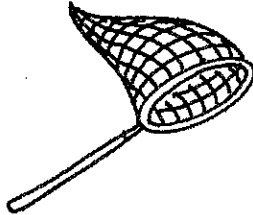

the

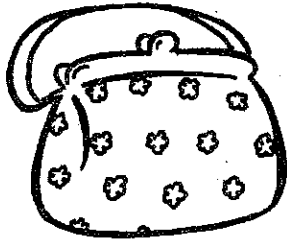

the



the

Directions: Read the first three phrases with children. Then have them read the last phrase and draw a picture to show what they like to eat. Then have them read the phrases again.

Name _____

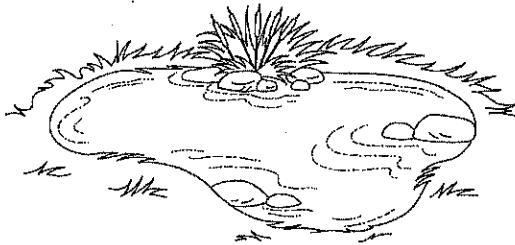

Directions: Have children circle the characters in the story and use the pictures to tell about the characters in the story. Then have them retell the story to one another.



Dear Family Members,
This Take-Home Book contains words your child is learning. After reading the story with your child, encourage him or her to read it to you. Then talk about what types of food you see and eat at picnics.

8



The

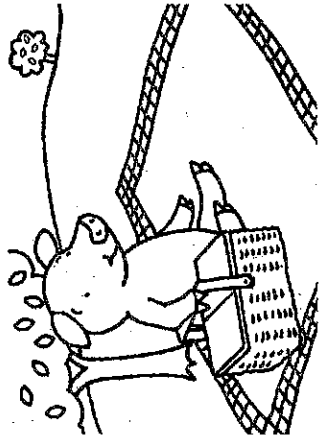
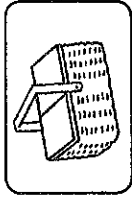

1

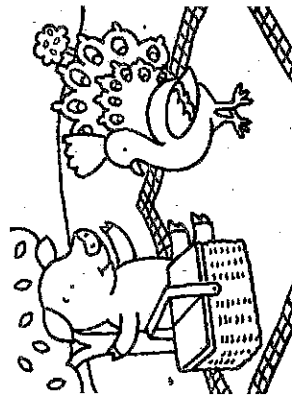

a



6

the

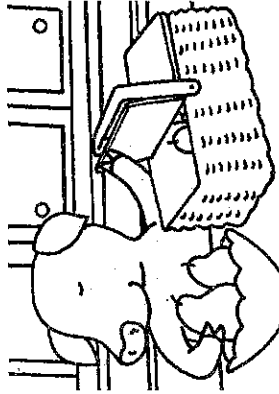
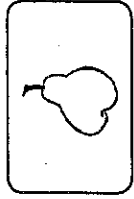

3

Directions: Help children cut and fold the book.

4

the

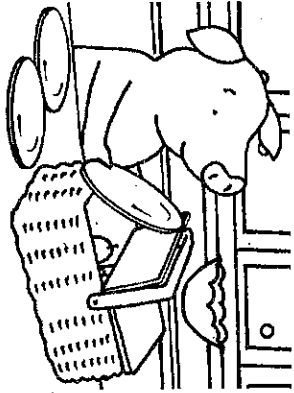
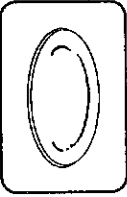

Fold

q



5

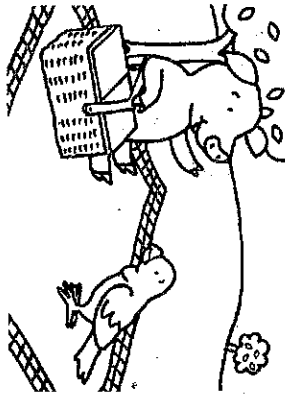

2

the

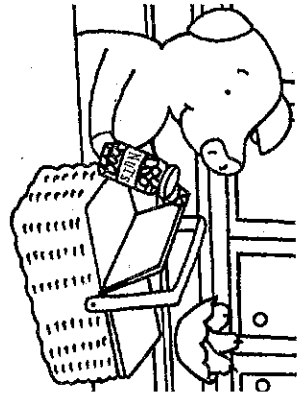
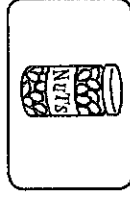

Fold

q

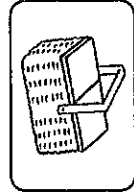

7

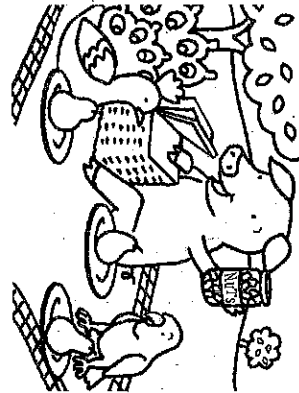

Name _____

Phonics: Cc
.....
Lesson 4 Day 5

Cc

c A C G c

a c B e C

C

c

C

c

Directions: Have children circle each uppercase C and underline each lowercase c. Then have them trace each letter and practice writing it on the line.

Name _____

Comprehension:
Characters
.....
Lesson 5 Day 1

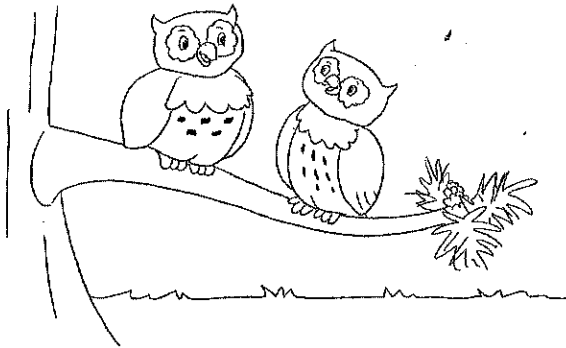
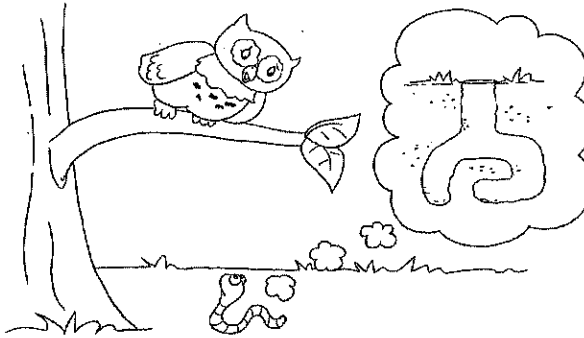
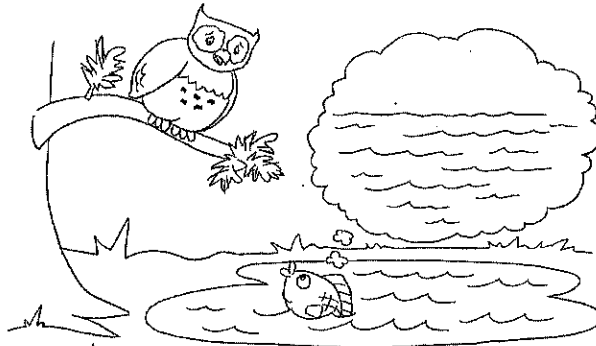

Directions: Have children use the pictures to name and tell about the characters in the story. Then have them retell the story to one another.

Name _____

High-Frequency
Word: go
.....
Lesson 5 Day 2



My



can go.



The

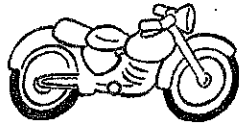

can go.



A

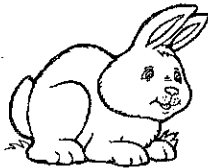

can go.



I go

Directions: Read the first three sentences to children. Then have them read the last sentence and draw a picture to show where they can go. Then have them read the sentences again.

Name _____

Comprehension:
Characters

.....
Lesson 5 Day 3



Directions: Have children circle the characters in the story and use the pictures to tell about the characters in the story. Then have them retell the story to one another.

I Go!

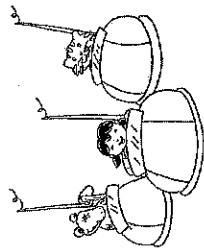

Fold

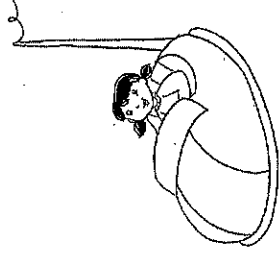

Dear Family Members,
This Take-Home Book contains words your child is learning. After reading the story with your child, encourage him or her to read it to you. Then talk about other ways animals or people can go.

8



1

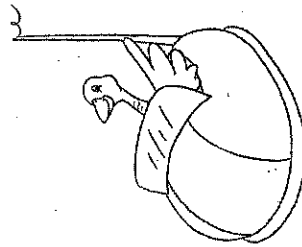

Fold

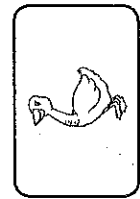
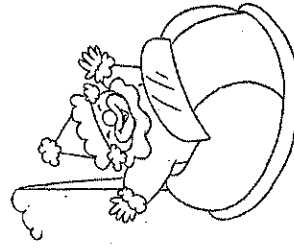

A turkey can go.

6

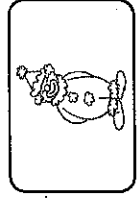

The girl can go.

3

Directions: Help children cut and fold the book.

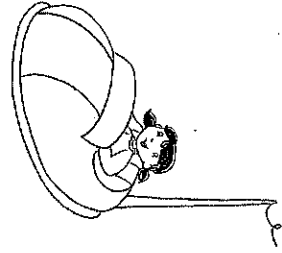

2- I can go.

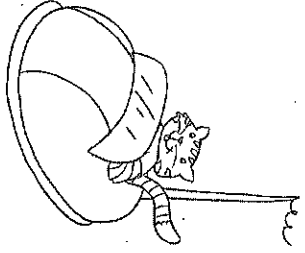

4 A can go.



Fold

Fold

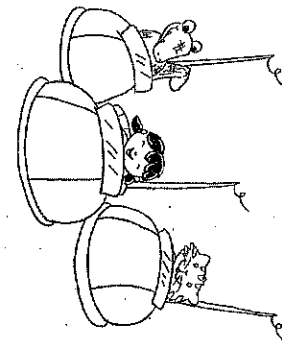

MY can go. 7

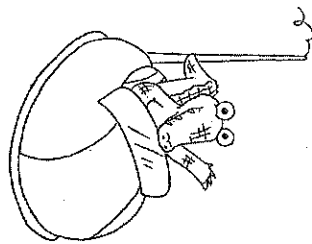
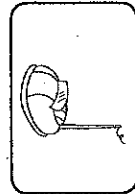

The can go. 5



Name _____

Phonics: Aa
.....
Lesson 5 Day 5

Aa

C A n N a

c P a p A

A

a

A

a

Directions: Have children circle each uppercase A and underline each lowercase a. Then have them trace each letter and practice writing it on the line.